

T O S S " U P

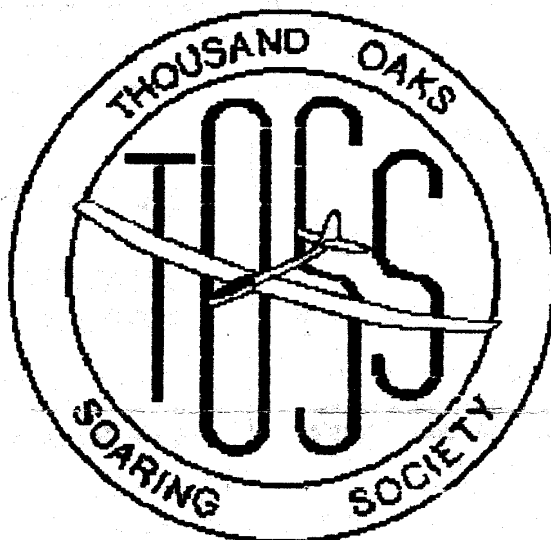

NEWSLETTER

DECEMBER 1989 T.O.S.S. P.O. BOX 1955 THOUSAND OAKS, CA. 91362

EDITOR : CHUCK GRISWOLD 1646 LA JOLLA DR THOUSAND OAKS CA. 91362

President:

Myles Moran
10428 Oso Ave.
Chatsworth, Ca. 91311
(818) 882-4687

Vice Presidents:

Eric Hendrickson
2486 Chaucer Pl.
Thousand Oaks, Ca. 91362
(805) 493-4210

Secretary:

Ed Oldenburg
951 Warwick Ave. *A2
Thousand Oaks, Ca. 91360
(805) 497-7463

Treasurer:

Chuck Griswold
1646 La Jolla Dr.
Thousand Oaks, Ca. 91362
(805) 495 1409

Club Winches:

Art McNamee	(818)	362-2822
Chuck Griswold	(805)	495-1409
Myles Moran	(818)	882-4687

Code-A-Phone: (805) 497-6367

Next Contest; JAN 13th 1990

C/D: ???

Type: ???

Next Meeting: Dec 31st. 1989???

Place: Oaks Mall
Next to Bullocks
Hillcrest Dr. T.O.

Time 7:30 p.m.



ERIC'S BLURB

Ho, Ho, Ho MERRY CHRISTMAS
 Where did the year go? It seems it went by in a blink of an eye. Elections were held at the last meeting. Edger Weisman is President. Congratulations, I think its great someone new is getting involved.

Boy, did we have a good turnout for the last contest of the year. The biggest we have had in a while with lots of sportsman. Just a couple of thoughts concerning contests. One, I believe all visiting flyers from other clubs should compete in the expert category, and secondly a number of you out there have expressed a desire to go to a handicapped scoring system for our monthly contests. The January MA has a system used by Diablo Valley Soaring Society for their contests and I asked Chuck to take this years scores and give it a try on them. I think the system will work with a little fine tuning plus it will make our contests much more interesting. As far as non club members or any new members coming out and flying they start out with no handicap and we could use their first four contests to determine their handicap. I think we should discuss this a the next meeting and give it a try.

So whats on for next year and What would I like to see? Hopefully better planning for all the events and bigger turnouts. First off I think we will have a better field to fly at. One with grass. Second, contests which are low key and more help for the newcomer. Third, more weekend fun flys. Fourth, meetings with an agende and a program of some sort. Fifth at least one BBQ and Night fly. Sixth, a successful Cross Country in September with Lots of teams and Lots of lift. If this sounds like the way to go let an officer know and help make it happen. Happy New Year Gang !!!

P.S. I'm going to school in Denver for the month of January to learn the 767. I'll be a little tough to get a hold of so don't think I'm ignoring you.

So Long

Eric

**THOUSAND OAKS SOARING SOCIETY
 MINUTES OF NOV. 29, 1989
 REGULAR MEETING No. 11**

There were twelve members present.

Myles called the meeting to order at 7:30 PM.

Chuck reported a balance of \$41.00 in the club treasury.

OLD BUSINESS

Eric reported that the X-Country event scheduled for Sept. 8 & 9, 1990 has been duly sanctioned by AMA. Eric will be the CD.

NEW BUSINESS

It was decided that this year's Xmas party would be held Dec. 23 at a place yet to be determined. Ed Oldenburg will arrange for the food. Chuck

C/D's For the Year.	
Jan 13th	Ed Weisman
Feb 10th	Chuck Griswold
Mar 10th	Art McNamee
Apr 14th	Ed Oldenburg
May 12th	Eric Hendrickson
Jun 9th	??????
Jul 14th	??????
Aug 11th	Don Northern
Sept 8th	X/C
Oct 13th	Richard Hartman
Nov 10th	Ralph Morgan
Dec 8th	??????



will send out "RSYP's" at \$5.00 per family.

\$300.00 was spent to reserve the same meeting room at the Oaks Mall thru to December, 1990.

Eric stated that a field at the Redwood school might be available to us.

Nominations for the executive officers for 1990 are as follows:

- President: Edgar Weisman
- Vice Pres: Eric Hendrickson
- Secretary: Bob Goldsmith
- Treasurer: Chuck Griswold
- Editor: Chuck Griswold

John VanHammersveld stated that he will be conducting classes in model building at the Youth Center next to the T.O. Library for juniors age 12 - 14, Jan 24 thru Mar 13, 1990, on Tuesdays from 3:30 to 5:30 pm.

The club voted 6 for and 6 abstain to conduct an F3H contest in September, 1991.

The meeting was closed at 8:45 pm.

SHOW AND TELL

Terry Koplan showed a remarkable new video that he has put together demonstrating the club's contest activities.

Chuck showed a David Fraser video demonstrating how the Princeton air tunnel testing was accomplished.

No raffle was held.

Ed Oldeberg

SOAP BOX

Well its' this time again. Since I missed Thanksgiving let me wish you a Merry Christmas and a Happy New Year. And a belated Happy Thanksgiving.

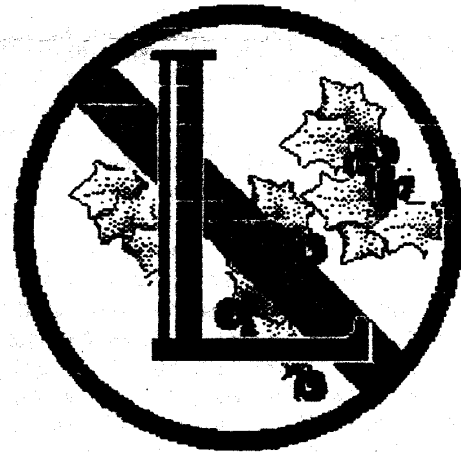

In case Bob Goldsmith hasn't noticed he is now secretary. — Big hand for Bob. The only reason he has been picked out to be honored in the newsletter, he was missing from the meeting at which he was honored by being nominated and elected. The other lucky ones are Edgar Weisman; President— Eric Hendrickson; YP. I got stuck with the treasurers job again. and since I'm the only one that can spell I retain the right to the newsletter. Of course if at any time any one would like this job please feel free to take it. It doesn't require a word processor or a computer, they just makes it much easier.

In this issue you will find a roster for 1989. We've had quite a year. 36 members, more than we've had in a while. You will also find a record of how we did in SC squared. Not bad for a small club. I won't steal Myles' fine farewell address to the club. — Well, he told me to tell you have a merry Christmas and a



Happy New Year, and fly at every contest that you can find. Art and Myles are trying to set a new club record. Unfortunately we don't have a plaque for the person attending the most contests for the year. The last word out of his mouth was "By!"

We've also had a lot of conversation on whether we are becoming a contest oriented club. In the newsletter if someone feels strongly one way or the other, drop me a line. Speaking of contests. Check out the standings. You'll recognize the first and second place names. Nothing unusual there. Look in third place Old Don Northern (the sleeper) jerks it away from Old Ed Old by thirty seven points. Our new president ain't no slouch. Watch out for Koplan and Yickers, a couple of old time winners. Also welcome our first LSF level five, Don Yickers, he joined our club at the December contest. I should publish the raw contest scores. You would be interested by the number of times the total points dropped is less than 50. That's not only with the winners but many of the also rans'. Compare that with the scores that were winning back in 1983 you will be surprised. Better equipment and better thumbs.

You will also find a new membership form. Put that to use right now, I'll wait. — did you fill it out and include your frequency. Did you write out a check and include it in the envelope, stamp. Now go out and drop it in the mail box and put the red flag up. What a group. I just heard 39 mail box lids slam shut.

OK Guy's. You won't have me to knock around until next month.

Bye for now

Chuck

THE NEWLY APPOINTED PRES

MERRY CHRISTMAS.

Thanks for the job--- I think!

Eric and I are working on flying sights. We have at least three lined up and need to check them out with some of the club fliers.

The club also needs C/Ds for the months of June July and December. We should have the type of contests you are planning to host if they are not the standard add em up or a 357 type.

*The Pres
Edgar Weisman*



I wonder if they got the HO cubed

I don't know, but I'll bet they don't get the circle "L"





EXTERNAL SWITCH/BATTERY CHECK/CHARGE PLUG

From the Central Arizona Soaring League

The idea isn't new but I will explain how I installed a phone jack in my plane which serves all the functions in the title. My first application was a 1.5 meter BODST (Bird of Daylight Savings Time) which I leave completely assembled and never remove anything, not even the hatch. The phone jack serves all my needs. The female portion, called the jack, is mounted in the side of the aircraft while the male portion, called the plug, has a flag attached and is externally installed to turn the plane on and off.

1. ON - OFF switch with plug installed and a red flag hanging from the plane when the switch is off. there is no way to accidentally bump this switch and turn off the plane just before launch. When in doubt you watch the bird as it flies away from you and if you see a red flag flapping out the side you know you're into free flight instead of R/C.

2. The battery checker plugs into the same jack which is especially handy on the small battery pack used in HLG.

3. And back home or at the field we plug the charger into the same jack.

So first the parts list:

PHONE JACK, SUBMINI (2.5mm)

Radio Shack 274-292

PHONE PLUG, SUBMINI (2.5mm)

Radio Shack 274-290

They come 2 per pack so get extra plugs for your charger and battery checker. You can use other jack/plug combinations but be sure it is a CLOSED CIRCUIT tupe jack.

The trick is to wire the switch portion of the jack on series with the positive wire (red) from the battery to the

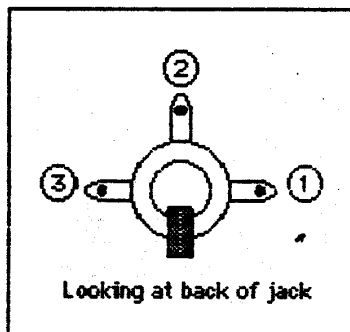

receiver. This switch is normally closed which means no plug installed =power on, plug with flag installed =power off. If we stop here we would have an ON- OFF switch but no way to measure or charge the battery. The plug would only have access to the positive side of the battery. What we need to do is tap into the negative (black) wire from the battery to the receiver, i.e. leave the wire as is but attach an additional wire and connect it to terminal 3. The easiest way to do this is cut the negative (black) wire and splice the ends with the third wire which runs to terminal 3.

Be sure all splices are well insulated.

The plug for the charger or battery checker is wired with its tip positive (+ or red)

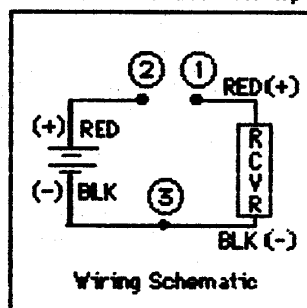

and its body negative (- or black). To save changing all your regular male plugs (Futaba Airtronics etc.) on your chargers or battery checkers you can make one

jumper cable with one end being the new phone plug and the other end your regular female plug.

Ed Parrish

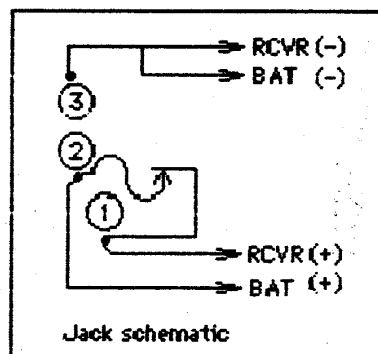

Max score DEC 3000
 Highest T.O.S.S. score DEC 2965

#	NAME	CLUB	TOTAL	JAN	FEB	MAR	APR	MAY	JUN	AUG	SEP	OCT	NOV	DEC
1	YURTS	TOSS	7982	996	997	1000	1000	0	0	1000	0	1000	1000	988
2	HENDRICKSON	TOSS	7853	973	969	983	969	996	986	998	0	0	0	980
3	NORTHERN	TOSS	7616	898	993	0	961	863	975	963	0	0	0	982
4	OLDENBURG	TOSS	7579	0	1000	871	917	884	997	1000	0	0	0	943
5	GRISVOLD	TOSS	7446	907	0	934	952	795	996	0	0	888	996	979
7	HARTMAN	TOSS	7111	804	938	882	907	817	909	0	0	874	0	980
8	WEISMAN	TOSS	6852	678	978	0	780	911	835	923	0	840	908	0
6	KOPLAN	TOSS	6555	0	0	0	986	961	1000	982	889	986	0	752
13	VICKERS	PSS	6353	886	919	948	0	0	0	727	0	939	987	947
9	McNAMEE	TOSS	6315	946	0	0	963	0	0	809	896	871	859	970
14	LINDGREN	TOSS	4726	0	0	846	951	0	972	0	990	0	0	966
10	MORGAN	TOSS	4653	958	919	979	0	965	0	0	0	0	831	0
11	GOLDSMITH	TOSS	4423	792	0	418	865	682	942	0	724	0	0	0
12	MORGAN	TOSS	4410	932	915	0	0	782	909	0	872	0	0	0
15	SVAN	TOSS	3299	0	928	0	623	884	866	0	0	0	0	0
16	MEREDITH	TOSS	1721	876	845	0	0	0	0	0	0	0	0	0
17	HOLLOWAY	TOSS	1291	0	490	367	434	0	0	0	0	0	0	0
18	SAREN	PSS	1000	1000	0	0	0	0	0	0	0	0	0	0
19	MBLEY	TOSS	934	0	0	0	934	0	0	0	0	0	0	0
20	McNAMEE D.	TOSS	902	0	0	0	902	0	0	0	0	0	0	0
21	OMSTAD	TOSS	895	895	0	0	0	0	0	0	0	0	0	0
22	DOUGLAS J	SVSA	823	0	0	823	0	0	0	0	0	0	0	0
23	VAN HAMERSVELD	TOSS	788	442	0	346	0	0	0	0	0	0	0	0
24	SVET	TOSS	590	0	0	0	0	0	590	0	0	0	0	0

2 METER CONTEST
 NORMALIZED TO 1000

#	NAME	CLUB	TOTAL	JAN	FEB	MAR	APR	MAY	JUN	AUG	SEP	OCT	NOV	DEC
1	YURTS	TOSS	7985	1000	990	0	1000	1000	0	1000	0	1000	1000	995
2	HENDRICKSON	TOSS	7860	0	960	1000	982	966	1000	991	0	0	983	1000
3	OLDENBURG	TOSS	6168	0	1000	969	746	728	0	0	0	833	952	940
4	GRISVOLD	TOSS	5640	0	0	0	0	890	943	0	854	993	970	986
5	VICKERS	PSS	3231	823	0	0	0	0	0	734	0	714	0	940
6	VAN HAMERSVELT	TOSS	2599	546	0	361	485	0	0	553	0	0	0	653
7	HOLLOWAY	TOSS	2418	0	0	534	917	0	966	0	0	0	0	0
8	MEREDITH	TOSS	1951	0	0	0	0	0	0	0	0	0	975	976
9	MORGAN	TOSS	1660	0	0	916	0	0	0	0	0	0	744	0
10	HARTMAN	TOSS	1365	0	0	733	0	0	0	0	0	0	0	633
11	MBLEY	TOSS	922	0	0	0	922	0	0	0	0	0	0	0
12	MES	SCSA	875	0	0	0	0	0	0	875	0	0	0	0
13	KOPLAN	TOSS	844	0	0	0	844	0	0	0	0	0	0	0
14	B. LYTLE	SCSA	798	0	0	0	0	0	0	0	0	798	0	0
15	WEISMAN	TOSS	694	0	0	0	0	0	0	0	0	0	365	330
16	VOSS	SCSA	642	0	0	0	0	0	0	642	0	0	0	0
17	J. LYTLE	SCSA	528	0	0	0	0	0	0	0	0	528	0	0
18	VALLIS	TOSS	250	0	0	0	0	250	0	0	0	0	0	0

SPORTSMAN CLASS NORMALIZED TO 1000

#	NAME	CLUB	TOTAL	AUG	SEPT	OCT	NOV	DEC
1	MORGAN	TOSS	4808	1000	953	940	960	954
2	GOLDSMITH	TOSS	4241	535	793	1000	1000	915
3	SVET	TOSS	2587	972	642	0	0	973
4	VAN HAMERSVELT	TOSS	2011	0	401	490	453	667
5	D. HENDRICKSON	TOSS	1947	947	1000	0	0	0
6	BUTKOVIC	PSS	1000	0	0	0	0	1000
7	LEAL	TOSS	927	0	0	0	0	927
8	MES	SCSA	829	829	0	0	0	0
9	VOSS	SCSA	744	744	0	0	0	0
10	KOVACH	SCSA	722	722	0	0	0	0
11	VALLIS	TOSS	404	0	0	0	0	404

TUSS ACTIVE ROSTER 1990

Pa/D last	first	ama	phone	street	city	st.	zip	frecuencias
BORSTELMANN	CRAIG	APP	805 498 2987	674 BLUE OAK AVE.	THOUSAND OAKS	CA.	91320 40	
BUDOLICH	NICK		147697 714 854 3689	19366 SERRA BELLO RD.	IRVINE	CA.	92715 39,40,50,56	
ELLIS	JOHN		304647 805 388 5674	1961 VIA MONTECITO	CANARILLO	CA.	93010 56	
GOLDSMITH	BOB		12351 805 529 2441	12792 WINTER AVE.	MOORPARK	CA.	93021 16,24,40,48,	
CRISWOLD	CHUCK		12108 805 495 1409	1646 LA JOLLA DR.	THOUSAND OAKS	CA.	91362 56,38,22,54,26,	
HARTMAN	RICHARD		111039 805 488 6136	1852 SAUFORD ST	OXNARD	CA.	93033 44,46,48,52,54,56	
HELGSON	DENNIS		104726 818 705 4872	6545 VILBER AVE.	RESEDA	CA.	91335	
HENDRICKSON	ERIC		136198 805 493 4210	2486 CHAUCEY PL.	THOUSAND OAKS	CA.	91362 22,24,26,30	
HOLLOWAY	GREG		262765 805 483 8170	1853 IVES AVE. #162	OXNARD	CA.	93033 48,50	
KOPLAN	TERRY		71615 818 889 6984	30434 V. RAINFOY CREST DR.	AGOURA HILLS	CA.	91301 40,56,--	
LEAL	MICHAEL		334482 805 529 7535	844 CHARLES ST.	MOORPARK	CA.	93021 20,24,28	
LINDGREN	RON		35111 805 523 1577	6421 CORNELL CIR.	MOORPARK	CA.	93021 48,52,56	
LOE	DAVID		331398 805 644 1527	5961 CANNON CT.	VENTURA	CA.	95003 24	
MCINTYRE	TODD		192744 805 482 2841	2417 LA SIERRA CT.	CANARILLO	CA.	93010 38	
MCNAMEE	ART		7417 818 362 2822	14950 YOUNGDALE PL.	SAN FERNANDO	CA.	91342 53,0	
MCNAMEE	DON		48996 805 525 3145	2291 N. HIETTER	SIMI VALLEY	CA.	93063 46,50,54	
MEREDITH	MAYNE		916 547 4207	5170 SPRIG WY.	ANDERSON	CA.	96007	
MESSING	JOE		67763 805 527 1940	6482 MELIA ST	SIMI VALLEY	CA.	93063 40,44,46,50	
MICHTSCH	GURR		222833 818 991 0666	6012 COLOONY DR.	AGOURA HILLS	CA.	91301 40,44,46,48,	
MICHTSEN	ROBERT		222832 818 991 0666	6012 COLOONY DR.	AGOURA HILLS	CA.	91301 40,44,46,48	
MORAN	MYLES		18426 818 882 4687	10428 OSO AVE.	CHATSWORTH	CA.	91311 every frequency known to man	
MORGAN	RALPH		805 484 7728	2120 GORMAN STREET	CANARILLO	CA.	93010	
MOWRY	BRUCE		67157 805 985 7032	2700 PENINSULA RD. #253	OXNARD	CA.	93033 42,46,50,56	
NIBLEY	BILL		94170 805 526 6754	2106 LATHAM ST.	SIMI VALLEY	CA.	93065 44	
NORTHERN	DON		28279 805 523 1018	3977 WILLOWCREEK Ln.	MOORPARK	CA.	93021 40,48,52	
OLDENBURG	ED		106776 805 497 7463	951 YARWICK AVE. #A2	THOUSAND OAKS	CA.	91360 53,3	
ONSTAD	BOB		501 389 6203	P.O. BOX 287	HATFIELD	AR.	71947	
SCHOLL	DON		139081 805 484 3233	1557 PRIMA CT	CANARILLO	CA.	93010	
SWAIN	DAVID		13577 805 485 9990	728 ERICA PL.	OXNARD	CA.	93030 44,43,54	
SVET	BOB		83233 805 388 9619	2600 PORDEROSA DR APT.15	CANARILLO	CA.	93010 42,54	
VAN HANBERSVELD	JOHN		136313 805 492 5904	2826 N MAR ETTA CIRCLE	THOUSAND OAKS	CA.	91360 40,50,56	
VICKERS	DON		7074 818 792 5612	3310 DEL VINA	PASADENA	CA.	91107 38,61,PETER	
WEISMAN	EDGAR		67651 805 496 0611	752 CAMINO VALLES	THOUSAND OAKS	CA.	91360 32,40,32	
WIECHERT	JIM		805 525 3327	1791 GLENVIEW AVE	SIMI VALLEY	CA.	93063	
WILLIS	BEN	APP	805 495 7404	196 QUAILS TRAIL	THOUSAND OAKS	CA.	91361 22	
WOOLSEY	BEVERLY		818 991 2544	5892 CAPE HORN DR	AGOURA	CA.	91301	
WURTS	JOE, JAN		40516 805 254 3525	23527 AVENIDA RONADA	VALENCIA	CA.	91355 16,20,46	
ZANGHEISTER	CHRIS		805 483 3526	1594 VIA LA SILVA	CANARILLO	CA.	93010 32	

SC²

RESULTS

ANNUAL STANDINGS (FINAL)

Name	Status	Club	Score	Contests	Name	Status	Club	Score	Contest
1 WURTS, J	EXPERT	TOSS	4924.2	5	54 BONANNO, T	SPORTSMAN	SULA	1872.9	2
2 MARTIN, T	EXPERT	HSS	4817.0	5	55 CLARK, D	EXPERT	NCC	1837.1	2
3 MORAN, M	EXPERT	TOSS	4785.1	5	56 CLIFTON, G	SPORTSMAN	SWBA	1807.9	2
4 FINK, D	EXPERT	SULA	4749.8	5	57 SHELBY, R	SPORTSMAN	SWBA	1796.3	2
5 HENDRICKSON, E	EXPERT	TOSS	4617.8	5	58 STARK, T	EXPERT	PSS	1793.8	2
6 GARNER, R	EXPERT	HSS	4608.4	5	59 WHITE, L	SPORTSMAN	HSS	1771.2	2
7 STALLS, J	EXPERT	HSS	4600.9	5	60 PUCHALSKI, M	SPORTSMAN	SULA	1767.3	2
8 SLIFF, B	EXPERT	HSS	4569.4	5	61 NITTER, D	EXPERT	PSS	1734.1	2
9 BRISWOLD, C	EXPERT	TOSS	4533.2	5	62 LOMERY, R	EXPERT	HSS	1731.4	2
10 JENKINS, H	EXPERT	SWBA	4434.1	5	63 DAVIS, J	SPORTSMAN	SWBA	1634.7	2
11 JOY, G	EXPERT	HSS	4386.9	5	64 WILSON, D	SPORTSMAN	ELDOR	1599.3	2
12 RICHARDSON, P	EXPERT	HSS	4386.7	5	65 PETTEN, M	SPORTSMAN	SWBA	1589.9	2
13 McNAMEE, A	SPORTSMAN	TOSS	4333.8	5	66 FEDELLECK, J	EXPERT	SULA	1588.7	2
14 SANDRONI, H	SPORTSMAN	SULA	4254.9	5	67 NEWLOVE, J	SPORTSMAN	NCC	1576.2	2
15 ZINK, D	EXPERT	HSS	4251.1	5	68 KUTCH, N	SPORTSMAN	HSS	1557.6	2
16 CRON, A	EXPERT	HSS	4207.1	5	69 AKER, I	EXPERT	SULA	1556.7	2
17 OLDBERG, E	EXPERT	TOSS	4182.2	5	70 ANDERSON, G	SPORTSMAN	NONE	1531.1	2
18 HOLLEY, M	SPORTSMAN	SWBA	4072.3	5	71 GLASS, R	SPORTSMAN	PSS	1506.1	2
19 STAFFORD, I	EXPERT	NCC	4051.0	5	72 GOLDSMITH, B	SPORTSMAN	TOSS	1478.5	2
20 CHASTELER, F	EXPERT	HSS	3963.1	5	73 BATES, J	SPORTSMAN	NCC	1475.7	2
21 DOUGLAS, I	EXPERT	PSS	3740.7	5	74 INGBRITSON, G	SPORTSMAN	SWBA	1465.4	2
22 EDGER, D	EXPERT	PSS	3736.8	4	75 PERKINS, D	EXPERT	PSS	1452.3	2
23 ATMELL, B	EXPERT	SULA	3614.4	4	76 PANTZAR, D	EXPERT	HSS	1328.5	2
24 MATSUMOTO, B	EXPERT	PSS	3598.8	4	77 POLLSON, G	EXPERT	HSS	1245.1	2
25 MEINERS, K	EXPERT	SULA	3568.3	4	78 SMITH, J	EXPERT	PSS	1149.6	2
26 SIREN, J	EXPERT	PSS	3467.6	4	79 KOPLAN, T	EXPERT	TOSS	989.9	1
27 TILLMAN, N	EXPERT	NCC	3305.4	4	80 BRATRUD, R	EXPERT	NONE	981.9	1
28 SMITH, M	EXPERT	NCC	3293.3	4	81 JOLLY, L	EXPERT	SULA	980.2	1
29 OLSEN, P	SPORTSMAN	SWBA	3272.3	4	82 NORTHERN, D	EXPERT	TOSS	967.5	1
30 BURNS, R	EXPERT	PSS	3246.8	4	83 BRANDT, D	EXPERT	NONE	938.7	1
31 HARRIS, P	EXPERT	HSS	3191.3	4	84 McCOLGAN, D	SPORTSMAN	SWBA	926.1	1
32 DOIG, A	EXPERT	NCC	3151.4	4	85 KEIL, D	SPORTSMAN	NCC	925.3	1
33 VICKERS, D	EXPERT	SULA	3120.7	4	86 CHASTAIN, B	SPORTSMAN	PSS	922.5	1
34 THOMAS, R	EXPERT	HSS	3040.9	4	87 HODGES, F	SPORTSMAN	NCC	920.4	1
35 RATNER, M	SPORTSMAN	PSS	2989.6	4	88 BENZ, D	SPORTSMAN	ISS	901.0	1
36 OLSEN, R	SPORTSMAN	SWBA	2936.1	4	89 PARSONS, J	SPORTSMAN	HSS	901.0	2
37 LUEKEN, J	EXPERT	NCC	2905.1	4	90 McNAMEE, D	SPORTSMAN	TOSS	898.6	1
38 RAYMOND, K	EXPERT	NCC	2852.5	4	91 ROBERTS, G	EXPERT	PSS	897.6	1
39 BILLMAN, T	EXPERT	PSS	2761.3	4	92 NEMECEK, D	EXPERT	HSS	894.2	1
40 SPENCER, R	EXPERT	SULA	2745.8	4	93 MEININER, T	EXPERT	PSS	874.0	1
41 BITZBERGER, J	SPORTSMAN	SWBA	2680.3	4	94 SCHWENNER, K	SPORTSMAN	NCC	871.9	1
42 FINK, S	SPORTSMAN	SULA	2597.3	4	95 LANDRETH, D	EXPERT	SWBA	868.6	1
43 BOTKIN, V	SPORTSMAN	ELDOR	2521.9	4	96 STAHLHEBER, F	EXPERT	NCC	865.2	1
44 CHASTELER, T	EXPERT	HSS	2417.1	4	97 COHEN, R	SPORTSMAN	ELDOR	853.0	1
45 HENDRY, S	SPORTSMAN	HSS	2411.2	4	98 ADDIS, S	EXPERT	SULA	851.6	1
46 BUTKOVICH, D	SPORTSMAN	PSS	2328.7	4	99 GATTI, M	SPORTSMAN	PSS	848.4	1
47 FINKENBINER, K	EXPERT	NCC	2284.7	4	100 HIGGINBOTHAM, M	EXPERT	ISS	843.4	1
48 DANRICH, D	SPORTSMAN	HSS	2273.9	4	101 HUNTER, J	EXPERT	NCC	839.2	1
49 LASATER, J	SPORTSMAN	HSS	2271.3	4	102 BROOKS, N	SPORTSMAN	PSS	837.4	1
50 RODRIGUEZ, J	SPORTSMAN	ISS	2114.6	4	103 GILLETTE, R	SPORTSMAN	ELDOR	833.9	1
51 WEISHAN, E	SPORTSMAN	TOSS	2110.4	4	104 SADORF, S	SPORTSMAN	ISS	827.3	1
52 CONRAD, W	SPORTSMAN	HSS	2081.0	4	105 STOVALL, W	SPORTSMAN	HSS	825.7	1
53 PETERSEN, L	SPORTSMAN	SWBA	1980.3	4	106 McGUIRE, J	SPORTSMAN	SWBA	815.4	1

ONE MORE ENTRY AND TOSS WOULD HAVE FIRST

Name	Status	Club	Score
107 CHASTAIN, K	EXPERT	SULA	813.2
108 PROVIN, R	EXPERT	PSS	796.9
109 MORRISSEY, N	EXPERT	ELDOR	743.2
110 STEVENS, J	EXPERT	ELDOR	735.3
111 HONELL, J	SPORTSMAN	ELDOR	732.0
112 BAUDER, K	SPORTSMAN	ISS	720.5
113 GILMAN, R	EXPERT	NCC	746.5
114 SHURT, H	EXPERT	SULA	737.9
115 OLSEN, H	SPORTSMAN	SULA	729.0
116 DREHRY, B	SPORTSMAN	PSS	724.0
117 AMES, J	SPORTSMAN	HSS	724.5
118 HALLING, G	SPORTSMAN	SWBA	696.7
119 HALLFORD, P	SPORTSMAN	PSS	696.7
120 STOWERS, R	EXPERT	SULA	690.2
121 BIRDS, D	SPORTSMAN	HSS	667.5
122 SILVA, M	SPORTSMAN	ISS	653.5
123 SHAW, B	SPORTSMAN	NONE	650.0
124 LUPPBERGER, J	EXPERT	NONE	616.8
125 FARLESS, D	EXPERT	PSS	603.4
126 LEPELLA, F	EXPERT	PSS	593.7
127 BECK, R	SPORTSMAN	NCC	572.3
128 STOKER, P	EXPERT	SULA	578.0
129 DURHAM, J	EXPERT	SULA	577.5
130 LONG, D	SPORTSMAN	SULA	562.5
131 DEGREVE, P	SPORTSMAN	SULA	545.8
132 BLANKOLB, B	EXPERT	NONE	488.9
133 CAMERON, S	EXPERT	NONE	458.9
134 GRISANTTI, P	SPORTSMAN	NONE	429.7
135 BUZOLICH, N	SPORTSMAN	NONE	417.2
136 JONES, D	SPORTSMAN	SULA	377.4
137 KELLER, J	SPORTSMAN	HSS	313.8
138 SHAW, B	SPORTSMAN	NONE	313.8
139 PARRA, J	SPORTSMAN	SWBA	290.2
140 LABARRE, R	SPORTSMAN	TOSS	288.5
141 JONAS, T	SPORTSMAN	NCC	104.3
142 JONAS, T	SPORTSMAN	NCC	0.0
143 WARNER, G	SPORTSMAN	NCC	0.0

H.S.S. - 23,058.0
 T.O.S.S. - 22,504.2
 S.U.L.A. - 21,830.5
 P.S.S. - 19,228.8
 N.C.C. - 17,580.4
 S.W.S.A. - 12,233.3
 I.S.S. - 7,188.8

TEAM FINAL 1989